

**REQUIREMENTS FOR PACKAGING AND DESPATCH OF BIOLOGICAL MATERIALS
TO THE INSTITUTE FOR ANIMAL HEALTH, PIRBRIGHT LABORATORY, UK
FROM OVERSEAS**

The Department for Environment, Food and Rural Affairs licence allows the importation of biological material to IAH-Pirbright by AIRFREIGHT, normally to London Heathrow Airport. The Institute's nominated Broker will Customs 'clear' the shipment and it will be collected by a member of the institute staff so that no commercial freight companies are involved other than the airline.

If it is not possible to deliver samples by airfreight then a courier designated by the Pirbright Laboratory may be used if this has been agreed with the Pirbright Laboratory in advance of the shipment.

Availability of diagnostic services

The laboratory offers an international diagnostic service for foot-and-mouth disease, swine vesicular disease, rinderpest, peste des petits ruminants, African swine fever, bluetongue, African horse sickness, sheep and goat pox and lumpy skin disease. Details of the services available are to be found on our website at:

http://www.iah.ac.uk/ref_Labs/Ref_Labs.aspx

The free service for analysing samples from animals suspected to be infected with the above-mentioned viruses is available for up to 50 samples per country per year (except by prior agreement) and testing is carried out on behalf of the national regulatory authority, to whom results will be copied. OIE / FAO will also be informed. Samples, virus isolates and deduced characteristics of the samples, such as genetic and antigenic data may be passed to others in order to facilitate international disease control and for the purpose of research into the development of improved disease control capabilities.

Before selecting biological material the sender should check with the relevant Department at Pirbright about the samples required and the conditions for despatch. Sample collection advice and sample submission forms for investigation of suspected cases of vesicular disease viruses are available on our website at:

http://www.iah.ac.uk/ref_Labs/Ref_Labs.aspx

Notification of shipment

Before despatch, the shipment details must be agreed with the Pirbright Laboratory who must be given the flight number, the Air Waybill number, the date and time of expected arrival in UK and a point of contact for queries and to whom test results will be provided (name, telephone number, fax number, e-mail address).

Contact with the Pirbright Laboratory should be made either directly with the reference laboratory administrator via: e-mail: gareth.shimmon@iah.ac.uk Tel: +44 (0) 1483 231014 or if this is not successful via the central contact numbers:

Tel : +44 (0)1483 232446

Fax: +44 (0)1483 232621

Packaging requirements

Specimens for diagnosis of the pathogens listed above must be packaged according to PI650 requirement for UN3373 category B classification¹ unless exempt due to a minimal likelihood that pathogens are present (e.g. samples for serology)

It is essential that packaging ensures that the contents of containers, which break or leak in transit, cannot contaminate the outside layer of the parcel. Samples should be placed in a watertight primary container which should be individually wrapped in absorbent material and then placed in a watertight crush and leak proof secondary container. This may be surrounded by sealed freezer packs or dry ice² and must be enclosed in a strong outer packaging which should allow the release of carbon dioxide if card ice is enclosed.

A list of contents should be enclosed in a waterproof envelope between the secondary and outer packaging.

The parcel must only contain material that is to be processed at the Pirbright Laboratory, as none of the contents can be sent to other laboratories in the United Kingdom from the Pirbright Laboratory.

Labelling

The outer packaging of the parcel must be clearly labelled with the following information as shown in the diagram below

- Our import licence number, AHZ/1309/A (a copy of which should also be attached within an envelope to the outside of the package)
- The name and address of the Institute and in the case of parcels sent by airfreight the instruction that the package is “Airfreight package for the attention of Moonbridge, Unit 304, Bedfont Industrial Park, Challenge Rd, Ashford, Middlesex, TW15 1AX”
- The name and telephone number of the person responsible for sending the parcel.
- Infectious Substance Hazard Label stating that the package contains a “Biological Substance, Category B” Animal Diagnostic Specimen of no Commercial Value (Hazard for Animal Health, not for people).
- Flight Number
- Air Waybill Number
- Dry Ice Label (if necessary).

IAH, Pirbright Laboratory

19th November 2010

¹ Cultures of the pathogens listed above must be packaged according to PI602 requirement for UN2900 category A classification

² Under no circumstances must dry ice be placed in sealed containers due to the risk of explosion

Customs Declaration

P
E
R
I
S
H
A
B
L
E

**BIOLOGICAL SUBSTANCE,
CATEGORY B**

Animal Diagnostic Specimen of no
Commercial Value (Hazard for
Animal Health, not for people)

TO:

Institute for Animal Health, Pirbright
Laboratory, Ash Road, Pirbright,
Woking, Surrey, GU24 0NF UK
Tel: +44 (0)1483 232446

[Import Licence No.: AHZ/1309/A](#)

Airfreight package for the attention of
Moonbridge, Unit 304, Bedfont
Industrial Park, Challenge Rd,
Ashford, Middlesex, TW15 1AX

Keep at 4°C unless otherwise instructed

F
R
A
G
I
L
E

Name of sender

.....
.....
.....

.Phone number (24hr).....

DRY ICE UN1845kg (net weight)

Flight number

Air Waybill number

**Example of Packing and Marking for Category B Infectious Substances
(See Packing Instruction 650 for additional requirements)**

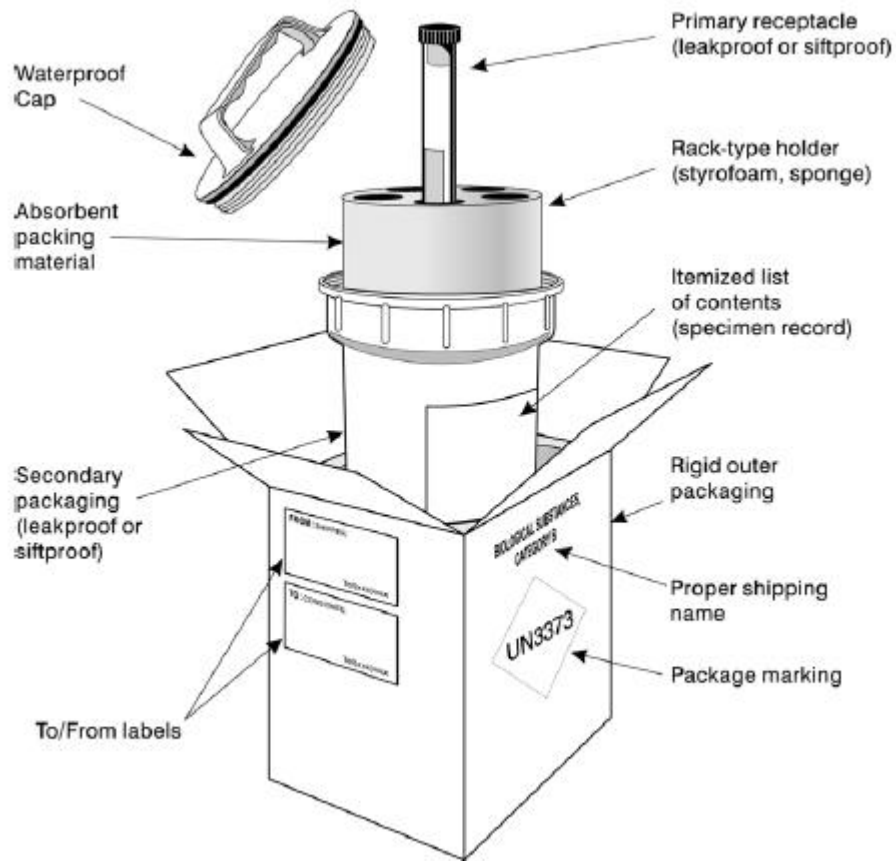

**Example of Packing and Marking for Category A Infectious Substances
(See Packing Instruction P602 for additional requirements)**

